

DIELECTRIC 

Small Capacity 2400 / 3200 Pole Mount Air Dryers

Operation Manual

MODELS 2400/3200 POLE MOUNT IB-352 REV. K PART NUMBER 60625



SPX 

**Notes, Cautions, and Warnings herein this manual
are used to prevent personal injury.**

Warning: To reduce the risk of fire or electric shock, do not expose this equipment to rain or moisture. For Indoor use only.

Warning: If the equipment is used in a manner not specified herein, the protection provided by the equipment may be impaired.

Warning: Turn off Power, Isolate power by unplugging or by locking separate disconnect before servicing.

Warning!: High Voltage Disconnect Power before working within

Caution: This Unit may start automatically at any time

NOTE: All machinery must be fitted with a means to isolate it from electrical energy sources. The isolator, must be capable of being locked when the operator is unable, from any of the points to which he/she has access, to check that the energy is off!

Caution: Use care when lifting compressor as compressor weight exceeds 60 lbs. (27.3 kg)

ATTENTION: Observe Precautions for Handling Electrostatic Sensitive Devices

Important Safety Instructions

1. Read and follow all instructions
2. Keep these instructions with the equipment
3. Heed all warnings, cautions and notes.
4. Do not block any ventilation openings.
5. Install in accordance with SPX Dielectric instructions
6. Do not defeat the safety purpose of the grounding type plug
7. Protect the power cord from being walked on or pinched.
8. Use Wrist Strap when handling ESD Sensitive Circuit Boards

WARNING! Risk of Electrocution

Isolate power by unplugging or by locking separate disconnect.



WARNING - RISK OR ELECTROCUTION



CAUTION - REFER TO ACCOMPANYING DOCUMENTS



WARNING - HOT SURFACE



ATTENTION - ELECTROSTATIC SENSITIVE DEVICE
OBSERVE PRECAUTIONS FOR HANDLING



CAUTION - LIFTING HAZARD



PROTECTIVE CONDUCTOR TERMINAL

TABLE I
TABLE OF CONTENTS

SECTION	TITLE	PAGE
1	INTRODUCTION	1
1.3	Before Installing	1
2	PRINCIPLE of OPERATION	1
3	DRY-PAK DRYER OPERATING CYCLE	2
4	RECEIVING and INSPECTION	3
5	INSTALLATION and START-UP	3
6	GENERAL MAINTENANCE	5
7	ADJUSTMENTS AND TESTS	5
7.1	Tank Pressure Switch	5
7.2	Back Pressure Regulator Adjustment	6
7.3	Excess Run Alarm	6
7.4	Replace Compressor Filters	6
7.5	Humidity Alarm Moisture Test	6
7.6	Compressor Rebuild	7
7.7	DRY-PAK Dryer Cycling Test	8
8	TROUBLE SHOOTING	9
8.1	Humidity Alarm Condition	9
8.2	Humidity Circuit Test	9
8.3	Dryer Cycling Interruption	9
8.4	Dry-down After Repair	10
9.0	SERVICE INFORMATION.....	10

LIST OF TABLES

TABLE	DESCRIPTION	PAGE
I	TABLE OF CONTENTS	i
II	TABLE OF LEADING PARTICULARS	ii
III	MAINTENANCE CHART	5
IV	LIST OF SPARE PARTS	12
V	ELECTRICAL COMPONENTS.....	18
VI	GLOSSARY OF TERMS	19

LIST OF ILLUSTRATIONS

FIGURE	DESCRIPTION	PAGE
1	TYPICAL POLE MOUNT DRYER.....	Cover
2	AIR FLOW DIAGRAM.....	2
3	DRYER CYCLE	3
4	DRYER ASSEMBLY	11
5	TYPICAL POLE MOUNT DRYER (front open)	13
6	TYPICAL POLE MOUNT DRYER (electrical module, inside view)	14
7	TYPICAL POLE MOUNT DRYER (electrical module, front view).....	14
8	TYPICAL POLE MOUNT DRYER (open top view)	15
9	TYPICAL POLE MOUNT DRYER (front open)	15
10	COMPRESSOR - EXPLODED VIEW.....	16
11	ELECTRICAL DIAGRAM (115V)	17

Table II
TABLE OF LEADING PARTICULARS

CHARACTERISTIC	MODEL 2400	MODEL 3200
NORMAL CAPACITY	2400 SCFD	3200 SCFD
EMERGENCY CAPACITY	3200 SCFD	4100 SCFD
WEIGHT	200 LBS	200 LBS
ELECTRICAL OPTIONS	115VAC, 60Hz 1ph	115VAC, 60Hz 1ph
AIR COMPRESSOR SIZE	3/4 HP	3/4 HP
OPERATING CURRENT/WITH HEATER	115V - 15 Amps	115V - 17 Amps
COMPRESSOR CIRCUIT PROTECTION	20 Amps(115V) C.B.	20 Amps(115V) C.B.
CONTROL CIRCUIT PROTECTION	1 Amps (115V) C.B.	1 Amps (115V) C.B.

DRY AIR DEWPOINT Below -40°F. (below -40°C.)
 DRY-PAK® twin-tower heatless dryer. Efficient, internal check-ball valving, purge controlled

DESICCANT DRYER TYPE by two-way solenoid valves.

OPERATING PRESSURE DRY-PAK® and compressor 60 PSIG (414 kPa), independent of tank pressure.(2400)
 DRY-PAK® and compressor 50 PSIG (345 kPa), independent of tank pressure.(3200)

TANK PRESSURE RANGE 25 PSIG (172 kPa) (compressor start) to 60 PSIG (414 kPa) (compressor stop).(2400)
 20 PSIG (138 kPa) (compressor start) to 50 PSIG (345 kPa) (compressor stop).(3200)

AIR COMPRESSOR TYPE Oilless, direct drive, motors are thermally protected.

REGULATED LINE PRESSURE Adjustable 2 TO 18 PSIG (14 - 124 kPa)

ALARMS - GENERAL Three independant alarm circuits that are monitored as a summary C.O. alarm. Factory configured for “Closed In Alarm”. Can be Re-configured for “Open In Alarm”.

HUMIDITY ALARM Operates at 2% RH., protects storage tank via Wet Air Bypass solenoid valve. Clears automatically when below 2% RH.

EXCESS RUN ALARM Adjustable, solid state timer, factory set @ 10 minutes. Range to 15 minutes.

POWER ALARM Active in event of service interruption, compressor or control-circuit breaker overload or unit turned off manually.

CABINET DIMENSIONS H 52.5in. x W 18 in. x D 18 in. (133.3 cm x 45.7 cm x 45.7 cm)

AIR TANK 1 cu/ft (28 L) - Mechanical 2nd agency rated

AIR TANK RELIEF VALVE Pop-off 75-80 PSIG (517 - 552 kPa)

CABINET CONTROL FEATURES. Ventilating Fan, Automatic cold weather shutter and Electric Heater.

WORKING TEMPERATURE -40°F to 125°F (-40°C to 52°C)

ADDED FEATURES Lightnig arrestor, Open Door trig, 15 Amp Ground Fault Receptacle and Maintenance Hour Meter

1.0 INTRODUCTION

1.1 This manual covers installation, operation, and maintenance with spare parts lists for Models 2400 and 3200 Pole Mount dryers.

1.2 These models from SPX Dielectric feature modular construction and incorporate the most reliable components available. The electrical control module, heatless dryer module (DRY-PAK), and the compressor module can easily and quickly be removed for maintenance when necessary. Cabinet flow-through forced air ventilation and vibration isolation optimize service life. Special consideration has been given to accessibility and ease of service.

1.3 BEFORE INSTALLING

READ THE MANUAL THOROUGHLY, then, with the manual as a reference, examine the air dryer. Learn to recognize the various components and the function performed by each.

2.0 PRINCIPLE OF OPERATION

2.1 The Model 2400 and 3200 Pole Mount Dryers are heatless, automatic regeneration, self contained units. The two models differ only in dryer and compressor capacity. The following descriptions are applicable to both models.

2.2 Ambient air is taken in by the compressor and compressed to approximately 60 PSIG (414 kPa), 50 PSIG (345kPa) on Model 3200. The compressed air flows through the heat exchanger where it is cooled by the cabinet ventilation fan.

2.3 The cabinet ventilation fan and the compressor always operate at the same time. The high capacity of the fan allows continuous compressor operation without overheating.

2.4 An adjustable delay timer monitors compressor operation. If the compressor operates continually for approximately 10 minutes the timer causes the excess run alarm to be active. The timer is adjustable from 1 to 15 minutes.

2.5 Next, the cooled, compressed air flows to the inlet fitting of the DRY-PAK dryer.

2.6 Moisture is removed from the compressed air by the DRY-PAK dryer (*see figure 3 and section 3.0 for explanation of the dryer operation*). When the air leaves the dryer, it is at a dewpoint of -40°F ($^{\circ}\text{C}$) or lower, which equals less than 1% RH. at 20°C .

2.7 The solid state dryer timer memory remains active whenever the dehydrator power switch is ON. The timer controls the complete drying cycle of the dryer. The cycle progresses only when the compressor is operating.

2.8 The moisture content of the air is monitored by a humidity sensor which is located in the manifold block. The humidity sensor will activate the humidity alarm if the relative humidity of the dry, compressed air rises above approximately 2% RH.

2.9 The dry air flows from the humidity sensor manifold and through the adjustable back pressure regulator, set to keep the pressure in the heatless dryer at a minimum of 60 PSIG(414 kPa), 50 PSIG (345 kPa)on Model 3200 during operation. The adjusted pressure of the back pressure regulator is shown on the back pressure gauge ONLY WHEN THE COMPRESSOR IS OPERATING. Maintaining a minimum of 60 PSIG (414 kPa), 50 PSIG (354 kPa) on Model 3200 pressure when the compressor is operating insures efficient dryer performance.

2.10 The dry air passes through the automatic humidity bypass solenoid valve and into the dry air storage tank. The humidity bypass solenoid is controlled by the humidistat. If there is moisture in the air stream, the bypass solenoid valve de-energizes and vents the air to atmosphere and does not allow moisture to go into the storage tank.

2.11 When the dehydrator is in service, the upper and lower limits of the tank pressure are controlled by the tank pressure switch. The tank pressure switch interrupts the dryer and compressor operation when 60 PSIG (414 kPa), 50 PSIG (345 kPa) on Model 3200 tank pressure is reached. The compressor and dryer start again when the tank pressure declines to 25 PSIG (172 kPa), 20 PSIG (138 kPa) on Model 3200. The tank pressure gauge is located on the tank panel. NOTE: Panel equipped with a 5 second time delay for start.

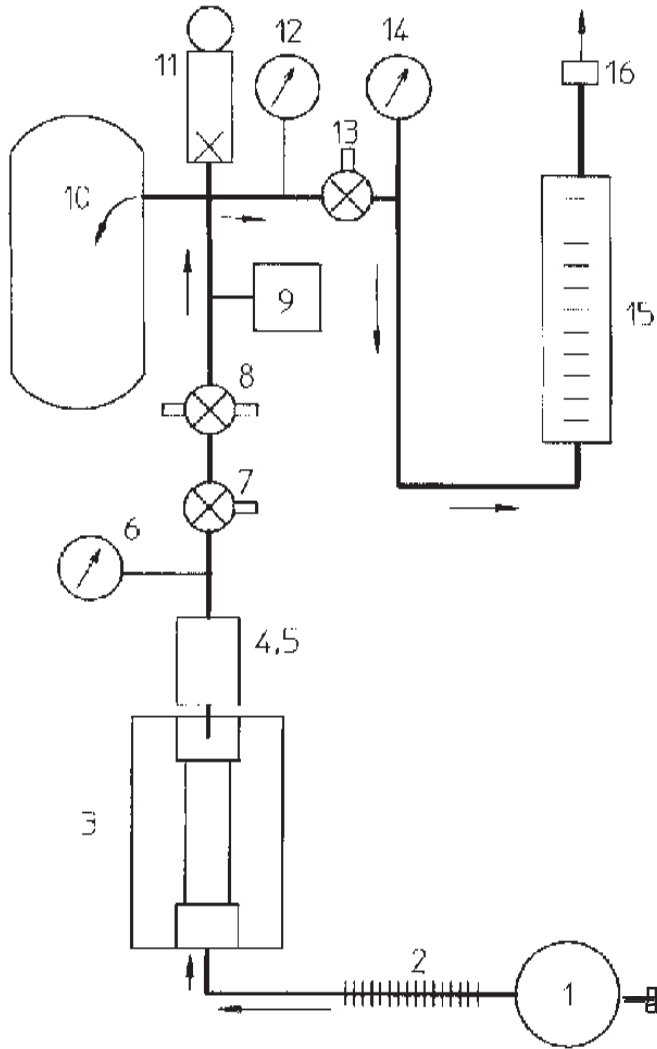

- | | |
|-----------------------------------|-------------------------------|
| 1. Motor Compressor | 9. Pressure Switch Start/Stop |
| 1A. Compressor Relief Valve | 10. Reservoir Tank |
| 2. Heat Exchanger | 11. Pressure Relief Valve |
| 3. Dryer Assembly | 12. Tank Pressure Gauge |
| 4. Manifold Block | 13. Line Pressure Regulator |
| 5. Humidity Sensing Element | 14. Line Pressure Gauge |
| 6. Back Pressure Gauge | 15. Flow Meter |
| 7. Back Pressure Regulator | 16. Dry Air Outlet Fitting |
| 8. Humidity Bypass Solenoid Valve | |

Figure 2
Air Flow Diagram

2.12 The tank is equipped with an ASME safety valve which is set at 80 ± 10 PSIG (552 kPa). Dry air flows from the tank to the adjustable line pressure regulator. The regulator maintains the required cable pressure, as shown on the line pressure gauge located on the tank panel. The air flow rate (measured in standard cubic feet per day, or SCFD) is shown on the output air flow meter.

2.13 The frequency and duration of compressor-dryer operation is determined by leakage of air from the cable system.

3.0 DRY-PAK DRYER OPERATING CYCLE

3.1 The two-way purge solenoid valves of the dryer handle only the purge air. Both the wet main air flow from the compressor and the dried air are controlled by the ball checks without appreciable pressure loss. This very low pressure drop is the key to the high efficiency of the DRY-PAK dryer.

The DRY-PAK dryer construction and cycle phases are shown in Figure 3.

There are four distinct phases of the one minute dryer cycle. Because the dryer operates only when the compressor is operating, the cycle may be interrupted during any cycle phase when the compressor stops. When the compressor restarts, the dryer will resume cycling in the same cycle phase as when it was interrupted.

Cycle phase 1..Right dehydration and left tower purge ..duration 25 sec. (2400), 27 Sec. (3200):

The right purge solenoid valve is closed, the left is open, venting the left desiccant tower to atmosphere. The check balls are held against the left valve seats by the higher pressure in the right desiccant tower. While most of the air being dried by the right tower leaves the outlet, a portion of the high pressure dry air passes through the orifice and expands at low pressure in the left tower which was wetted in the previous cycle. The expanding air flow picks up the moisture and carries it through the open purge solenoid valve outlet to atmosphere. At completion of cycle phase 1, the elapsed cycle time is 25 seconds.

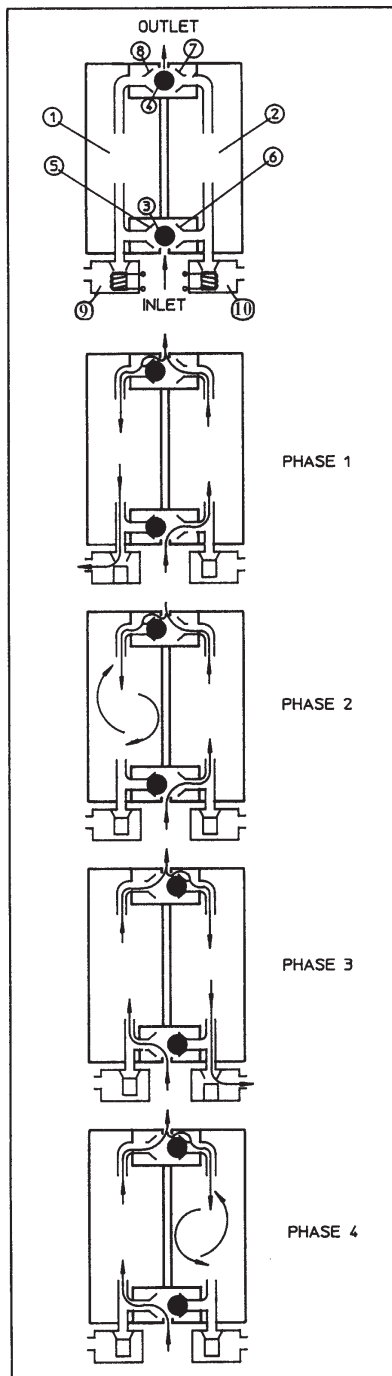

Figure 3
Dryer Cycle

Major details of construction:

- 1,2.... Left and right desiccant towers.
- 3,4.... Inlet and outlet check balls.
- 5,6.... Left and right inlet valve seat.
- 7,8.... Left and right outlet valve seat with
purge orifice.
- 9,10...Left and right purge solenoid valves.

**Cycle phase 2..Right dehydration and left dwell..
duration 5 sec. (2400), 3 sec. (3200):**

Both purge solenoid valves are closed and dry air continues to flow through the calibrated purge orifice until the air pressure in the left tower is equal to the air pressure in the right tower. At completion of cycle phase 2, the elapsed cycle time is 30 seconds.

**Cycle phase 3.. Left dehydration and right tower
purge..duration 25 sec. (2400), 27 sec. (3200):**

The left purge solenoid valve is closed, the right is open, venting the right desiccant tower to atmosphere. The check balls are held against the right valve seats by the higher pressure in the left desiccant tower. While most of the air being dried by the left tower leaves the outlet, a portion of the high pressure dry air passes through the orifice and expands at low pressure in the right tower which was wetted in the previous cycle. The expanding air flow picks up the moisture and carries it through the open purge solenoid valve outlet to atmosphere. At completion of cycle phase 3, the elapsed cycle time is 55 seconds.

**Cycle phase 4..Left dehydration and right dwell..
duration 5 sec. (2400), 3 sec. (3200):**

Both purge solenoid valves are closed and dry air continues to flow through the calibrated purge orifice until the air pressure in the right tower is equal to the air pressure in the left tower. At completion of cycle phase 4, the elapsed cycle time is 60 seconds.

4.0 RECEIVING AND INSPECTION

4.1 Shipping damage is unusual but not totally avoidable. Open the shipping container upon receipt and inspect the contents for hidden damage. If damage is evident, promptly file a hidden damage claim with the delivering transportation company.

5.0 INSTALLATION AND START-UP

5.1 The Model 2400 and 3200 Pole Mount can be mounted on a pole, a wall or on the floor. Pole Mount Hanger hooks and the Lower mounting bracket are provided with the unit. A Pole Mounting Top Bracket

P/N 98304 may be ordered separately if required.

5.2 To mount a unit to a pole or wall:

5.2.1 Position the top mounting bracket approximately three (3) inches below the level at which the top of the cabinet will be located.

5.2.2 Secure the top bracket to the pole (or wall) with a cross arm bolt of suitable length.

5.2.3 Remove the bottom mounting bracket from the cabinet.

5.2.4 Raise the cabinet into position using the two lifting lugs located at the upper rear of the cabinet. Position the two hooks onto the mounting bracket and secure by tightening the set screws in each hook.

5.2.5 Align the cabinet into place so that the unit hangs in a vertical position. Use a board or wedge between the pole and the back of the cabinet. Attach the bottom bracket loosely to the cabinet, with the angle of the bracket directed downward.

5.2.6 Position the bottom bracket to the pole or wall and tighten the hardware to secure the bracket to the cabinet.

5.2.7 Fasten the bracket to the pole or wall using a lag bolt (1/2 by 4-1/2" bolt is recommended size). Then remove the block or wedge from between the cabinet.

5.2.8 Open the unit door and top cover. Remove the accessory kit from the cabinet and compressor shipping hold down hardware.

5.2.9 Route 115 VAC, 60 Hz power line through the larger waterproof connector located on the right side of the unit. Remove the electrical terminal cover and install the power source to the unit. L1 is the far left terminal, L2 is the center terminal and ground is the far right terminal. Secure the waterproof connector by tightening clockwise the outside nut of the connector. Install the electrical terminal cover back onto the terminal block.

5.2.10 Route an alarm pair through the small water-

proof connector on the right side of the unit. Follow the labeled instructions located on the top cover to install the remote alarm wires. The accessory kit provides the resistors for the alarm installation. Factory Default wired for "Closed In Alarm" To Re-Configure for "Open In Alarm" See Notice on Electrical Module

5.3 Be sure to install an inlet filter into the inlet air opening below the cabinet. Verify that the cabinet ventilation fan exhaust opening at the rear is not obstructed.

5.4 Turn on both POWER and COMPRESSOR circuit breakers located on the electrical module panel. Verify that the back-pressure gauge on the lower inside of the front door shows 60 to 65 PSIG (414-448 kPa) 50 to 55 PSIG (414-379kPa) for Model 3200, pressure while the compressor is operating. If outside this pressure range *refer to: 7.2 Adjust Back-Pressure.*

5.5 Verify the purge cycling of the heatless dryer at the bottom of the door. When the compressor is operating a purge occurs at 30 second intervals, first from one and then the other tower purge solenoid valve. The purge air blast is audible and can be felt as it escapes from the plastic silencer on the purge solenoid valve. After the initial purge blast, a steady flow of purge air continues for 25 seconds (27 seconds on Model 3200). After 5 additional seconds (3 seconds on Model 3200), the opposite purge will occur. If the cycling is not as described, refer to section 8.3 Trouble Shooting Dryer Cycling Interruption. Close the cabinet door to insure maximum ventilation.

5.6 A humidity alarm is a common condition at initial start-up. This is due to an extended period of dryer inactivity, consequent to storage and shipping. The initial humidity alarm will normally clear automatically in 60 minutes (or less) of operation. For in depth information, refer to *8.2 Humidity Alarm Trouble Shooting.*

5.7 After the humidity alarm is cleared, loosen the lock-nut on the threaded stem of the line pressure regulator adjustment knob. Adjust the line pressure regulator to allow air to escape the outlet air fitting at a rate of approximately 50% of dehydrator capacity as shown on the outlet air flow meter. Temporarily

lock the regulator lock-nut to maintain this flow rate. When the tank pressure reaches 60 ± 2 PSIG (414 kPa), 50 PSIG (345 kPa) on Model 3200, the compressor will stop. The compressor will start again when the tank pressure declines to 25 ± 2 PSIG (20 ± 2 PSIG on Model 3200). If the tank pressure range exceeds these limits refer to: *7.1 Tank Pressure Switch Adjustment*.

NOTE:

The humidity alarm may become active when the compressor is not operating.

5.7.1 Install the provided outlet fitting onto the unit and connect 3/8" tubing (copper or poly-ethylene) to the outlet fitting.

5.8 Adjust the line pressure regulator to achieve the desired pressure as indicated on the line pressure gauge. When the line pressure is satisfactory, lock the setting by means of the regulator lock-nut.

6.0 GENERAL MAINTENANCE:

Periodic maintenance must be performed to insure continued reliable and efficient operation of the Pole Mount Dryer. Refer to laminated Maintenance Schedule attached to unit.

6.1 At intervals of 1000 hours of operation: Verify that the DRY-PAK dryer is cycling correctly. *Refer to Section 3.0.*

6.2 At intervals of 1000 hours of operation: Verify that the back pressure regulator is correctly adjusted *Refer to section 7.2.*

6.3 At intervals of 1000 hours of operation: Verify the adjustment of the tank pressure switch. *Refer to section 7.1.*

6.4 At intervals of 2000 hours of operation: Replace the compressor inlet filter elements. *Refer to section 7.4.*

6.5 At intervals of 2000 hours of operation: Test the humidity alarm circuit. *Refer to section 7.5.*

6.6 At intervals of 4000 hours of operation: Replace the compressor rings and valves. *Refer to: 7.6.*

7.0 ADJUSTMENTS AND TESTS:

7.1 Check or Change Tank Pressure Switch Setting adjustment.

NOTE:

Acceptable tank pressure at compressor start is 25 ± 2 PSIG (172 kPa), 20 PSIG (138 kPa) on Model 3200, and stop at 60 ± 2 PSIG (414 kPa), 50 PSIG (345 kPa) on Model 3200).

7.1.1 The tank pressure switch has been factory adjusted. Observe and record the start and stop pressures for reference before continuing.



WARNING!

RISK OF ELECTROCUTION - Before performing this procedure: Disconnect from the electrical power source

7.1.2 The tank pressure switch is located on the electrical module panel. With the module removed and from the back, the two adjuster nuts are visible. To adjust both the start and stop pressures (the total tank pressure range) turn only the nut on the center adjuster. About 2 1/8 FULL REVOLUTIONS of the adjuster nut changes the set-point 5 PSIG. Clockwise raises, counterclockwise lowers the setting. Install the electrical module after adjustment and close the cabinet door. Connect the power cord to the electric

PROCEDURE	Ref. Para.	1000 Hrs	2000 Hrs	3000 Hrs	4000 Hrs
Verify Dry-Pak Cycling	3.0	X	X	X	X
Verify Back Pressure	7.2	X	X	X	X
Verify Tank Pressure Switch Adjustment	7.1	X	X	X	X
Replace Inlet Air Filter Elements	7.4		X		X
Test Humidity Alarm Circuit	7.5		X		X
Replace Compressor Rings & Valves	7.6				X

TABLE III - MAINTENANCE CHART

outlet and restart the dehydrator. Again check the start and stop pressure to verify the tank pressure switch adjustment.

7.2 Check or Change Back Pressure Regulator Adjustment:

7.2.1 PREPARATION: Adjust the back pressure regulator only -- WHILE THE COMPRESSOR IS OPERATING AND THE TANK PRESSURE IS BETWEEN 25 AND 50 PSIG (172-345 kPa), 20 and 30 PSIG (138-207 kPa) on Model 3200.

Loosen the outlet air tube at the rear of the cabinet to increase the air flow rate. This will help to give more time to perform and validate the adjustment. Pull the back pressure regulator adjuster knob about 1/4 inch outward to the unlocked position.

7.2.2 Wait until a purge blast occurs from one of the purge solenoid valve silencers. Turn the adjustment knob clockwise to raise, or counterclockwise to lower the back pressure. The acceptable adjustment range is 60 to 65 PSIG (414-448 kPa), 50 to 55 PSIG (345-379 kPa) on Model 3200.

7.2.3 Continue to observe the back pressure gauge for not less than one full minute more. The first purge valve to purge after your adjustment will have purged a second time. This assures that you have observed the full timing cycle of the DRY-PAK dryer.

7.2.4 If the compressor stopped operating, or, if the tank pressure varied from the specified range before you completed your observation, repeat 7.2.2 and 7.2.3.

7.2.5 It is normal for the back pressure to rise slightly before a purge, or to fall slightly when the purge occurs. The normal extremes are approximately ± 5 PSIG (34 kPa). If the back pressure was much more erratic (± 20 PSIG (138 kPa) or more) proceed to section 8.3.

7.3 Check or Change Excess Run Alarm Timer Adjustment.

7.3.1 The excess run alarm timer (T2) is located, and identified, on the electrical module. Before mak-

ing adjustment, cause the dryer to run continually and measure the time delay from compressor start to alarm activation.



WARNING!

RISK OF ELECTROCUTION - Before performing this procedure: Disconnect from the electrical power source

7.3.2 After the power is disconnected, push and release the two fasteners at the top of the electrical module on the door. The adjustment range and direction of increase/decrease are shown on the timer label. Make only very minor adjustment at any one time and then check the alarm delay as in 7.3.1. If the alarm does not function, replacement of the delay timer is indicated.

7.4 Replace Compressor Filters.

7.4.1 Turn off the dehydrator. Press the black filter cap downward and turn it counterclockwise. Remove the cap, discard the old filter and wipe the cap clean with a rag. Install the new filter element and reassemble in reverse order. Each cylinder has one filter element.

7.5 Humidity Alarm Moisture Test.

7.5.1 Turn the dehydrator off and vent all the air pressure from the sensor manifold test valve. When the back pressure gauge indicates 0 PSIG, remove the sensor by turning the large hex nut at the top of the manifold counterclockwise. Remove the sensor carefully so that the sealing O-ring is not lost.

7.5.2 Blow on the sensor element to make it moist and then return it to the manifold. Be sure that the O-ring is in place, then hand-tighten the large hex nut (***do not use a wrench***).

7.5.3 Start the dehydrator and verify that the humidity alarm is active and that air escapes through the open port (port 3) of the humidity bypass solenoid valve.

7.5.4 While the alarm is active, move the humidistat test toggle to "TEST CLEAR" for a few seconds.

Verify that the humidity alarm clears until the test toggle is released. Close the cabinet door. After several minutes of operation the alarm will clear automatically.

7.6 Compressor Rebuild.



WARNING!

RISK OF ELECTROCUTION - Before performing this procedure: Disconnect from the electrical power source



WARNING!

Normal compressor operation will cause head temperature to exceed 100°C. Be very careful when handling a hot compressor.

7.6.1 Do not lubricate any part of the compressor. Do not allow petroleum products, caustics or solvents to contact any part of the compressor. Parts may be cleaned with soap and water followed by wipe down with a cloth dampened with clean water.

7.6.2 To remove the compressor from the cabinet:

a. Disconnect the flexible hose from the compressor outlet using two wrenches (11/16 inch and 3/4 inch open end or comparable adjustable wrenches).

b. Disconnect the electrical quick connect (S2/J2) which joins the compressor electrical harness to the cabinet electrical harness.

c. Loosen the nuts from the four support-shock mounts with a 1/2 inch open end wrench. Remove the nuts and washers.

d. Lift the compressor assembly free of the shock mounts and remove the compressor/mounting frame assembly from the cabinet. Remove the four 5/16 inch nuts, lock washers, flat washers and bolts holding the compressor to its frame.

7.6.3 Refer to figure 5, COMPRESSOR - EXPLODED VIEW before disassembly of compressor. Item numbers given in this procedure, refer to figure 10.

7.6.4 **DO NOT REMOVE THE INLET FILTER ASSEMBLIES (1) FROM THE CYLINDER HEADS.**

7.6.5 Loosen the four #2 phillips screws and remove the plastic compressor fan shroud (39).

7.6.6 Use a 3/4 inch open end wrench to loosen the manifold nuts (41) on the manifold tube (42) between the left and the right cylinder heads (20). **DO NOT REMOVE THE MANIFOLD TUBE UNTIL ONE HEAD HAS BEEN REMOVED!**

7.6.7 Use a 3/16 inch Allen hex wrench to remove the cylinder head and valve components (22, 23 and 24) from one cylinder. Next remove the manifold tube, and then the opposite cylinder head. It may be necessary to use a knife or razor blade to remove the gasket material (21 and 25) from the head and cylinder. Be very careful not to scratch the aluminum surfaces.

7.6.8 Remove the two cylinder screws (27) which hold each cylinder (26) and slide the cylinders outward, over the pistons (30). Remove the piston rings (28), piston seals (29) and piston rider rings (31) from the pistons.

7.6.9 Examine the heads, pistons and cylinders for scratches or scars on working surfaces. Clean the parts only with a cloth and soapy water if they are dirty or greasy. Do not reuse scratched components.

7.6.10 Install a new piston seal in one ring groove of one piston and hold it in place by installing a piston ring over the seal. Place the joint in the piston ring opposite to the joint in the piston seal. Be sure that the ring covers the entire seal all around the piston. Repeat with each of the 3 remaining seals and rings. If the joints of the piston rings on either piston are nearly aligned, rotate one ring until its joint is not less than 45 angular degrees from the adjacent ring joint.

7.6.11 Place a piston rider ring (31) on one piston and slide a cylinder gently over the piston rings and rider ring. Be sure that no part of the rider ring protrudes from the cylinder, and that the cylinder will slide smoothly on the piston. Attach the cylinder to the motor front bracket, using two screws. Tighten the screws **ONLY FINGER TIGHT**. Repeat for the

opposite cylinder of the compressor.

7.6.12 Rotate the motor shaft and move the pistons to the extreme outward position (top dead center). Move each cylinder so that it is even with the top of the piston. Torque the cylinder screws to 150 pound-inches (18.44 Nm). Place a flat bar vertically across the open cylinder. Rotate the motor shaft. The piston should contact the flat bar without lifting the bar from the cylinder surface. The cylinder gasket (25), when added, will provide the correct piston-to-valve clearance when the head assembly is secured.

7.6.13 The aluminum head, the head gasket and the outlet valve, each have 4 bolt holes at the corners and a single, smaller hole, (a “pilot” hole) for reference in aligning the components correctly. The aluminum valve plate, the inlet valve and the cylinder gasket each have 4 bolt holes at the corners, and two smaller holes (“pilot holes”) for the same purpose.

Follow this simple procedure when reassembling the head and valve components and the parts will be correctly positioned:

7.6.14 Hold the head in one hand, with its inside up, and with two head bolts protruding upward through the head. Align the pilot hole in the head gasket and the outlet valve, with the pilot hole in the head and place them on the head. The pilot hole in the head must still be visible through the pilot holes in the components. The outlet valve has a “finger” on one side, an oblong hole in the opposite side. The inside of the head must still be visible through the oblong hole in the outlet valve.

7.6.15 Place the aluminum valve plate on next, so one pilot hole aligns with that in the head, the outlet valve finger can be moved by pushing gently with a pencil through the outlet air passages of the aluminum plate and so that the inside of the head is still visible through the inlet air passages of the aluminum plate. Next add the inlet valve so that its finger covers the inlet air passages and the outlet valve finger can still be seen and can be moved with a pencil through the outlet air passages. Add the cylinder gasket, then loosely connect the assembly to the cylinder. Loosely install the manifold on the first head, after installing new manifold sleeves (40). DO NOT TIGHTEN

the head bolts at this time. Repeat with the opposite head.

7.6.16 Tighten the four Allen head screws of each head finger tight. Torque the screws to 120 pound-inches (13.83 Nm) using a 3/16 inch Allen hex wrench.

7.6.17 Install the compressor fan shroud with the four screws and washers previously removed.

7.6.18 Position the manifold and tighten the manifold nuts with a wrench, 1/2 to 3/4 turns more than hand tight.

NOTE!

Minor air leakage at the head-valve-cylinder joints is normal.

DO NOT SEAL the gaskets with joint compound or sealant as damage to the assembly will occur. Do not attempt to eliminate leakage by exceeding recommended torque values as distortion will result.

7.6.19 Replace the compressor on its frame with the four 5/16 inch bolts passing upward through the frame, riser blocks and compressor base plate. Install flat washers, lock washers and nuts on the bolts. Torque the nut/bolt assemblies to 20 foot-pounds (27.5 Nm).

7.6.20 Carefully reinstall the compressor into the cabinet so that the frame rests on all four shock mounts. Install the four lock washers and nuts, tighten to not more than 70 inch-pounds (8 Nm). Hold the outlet air fitting with a wrench while tightening the flexible hose nut. Reconnect the electrical quick-connect (J2/S2) before restoring the cabinet power cord connection.

7.7 DRY-PAK Dryer Cycling Test

7.7.1 The Dry-Pak dryer only cycles when the compressor is operating. The cycle timing is 25 seconds of purge and 5 seconds dwell (27 seconds purge and 3 seconds dwell on Model 3200 only). Loosen the air outlet tube at the rear of the cabinet, if necessary, to cause the dehydrator to continue operating for several minutes.

7.7.2 With the compressor operating and the back

pressure adjusted as per section 7.2, an audible purge should be heard each 30 seconds. A blast of air from the purging valve silencer can be felt simultaneously. 30 seconds later the opposite purge valve will provide the same indications. This is indication that the DRY-PAK dryer is cycling normally. If cycling is normal, tighten the air outlet tube. If trouble shooting, *refer to section 8.3.*

8.0 TROUBLE SHOOTING:

8.1 Trouble Shooting a Humidity Alarm.

8.1.1 The following is a list of conditions which can cause a humidity alarm and the order in which to proceed:

- a: Test for faulty alarm circuit (section 8.2.2).
- b: Test for low back pressure (section 7.2).
- c: Test for DRY-PAK dryer not cycling - refer to: 7.7 heatless dryer cycling test. and to: 8.3 *TROUBLE SHOOTING DRY-PAK DRYER CYCLING INTERRUPTION.*
- d: Back pressure falls to near 0 PSIG while compressor is operating. *Refer to: 8.3.3 PRESSURE FLUCTUATION.*
- e: Continual humidity alarm, but heatless dryer cycle, back pressure and operating duty cycle are normal. *Refer to: section 8.3.4.*
- f: Intermittent humidity alarm. Humidity alarm clears automatically after a period of continual operation. After a period of alarm free operation the humidity alarm reoccurs. *Refer to section 8.4.*
- g: If you have found and corrected an obvious cause of the humidity alarm and yet the alarm persists, *refer to section 8.5.*

8.2. Humidity Circuit Test

8.2.1 When trouble shooting a humidity alarm, first verify the operation of the humidistat, located on the electrical module at the top of the door.

8.2.2 If the humidity alarm is active and the amber

(yellow) LED on the humidistat is lit, verify the alarm by moving the test toggle to “Test Alarm”. If this action temporarily clears an amber alarm, the humidistat is operating correctly. Refer to 8.2.3 “Valid Open Alarm”. If the test toggle will not temporarily clear the amber LED when it is lit, replace the humidistat.

8.2.3 If the humidity alarm is active and the red LED on the humidistat is lit: verify the alarm by moving the test toggle to “Test Clear”. If this action temporarily clears the alarm, the humidistat is operating correctly. Refer to 8.2.3: “Valid Humidity Alarm”. If the test toggle will not temporarily clear the red LED when it is lit, replace the humidistat.

8.2.4 Valid Open Alarm, If the amber LED on the humidistat is lit and the test toggle will temporarily clear it, (section 8.2.2) there is an open condition in the sensor circuit. Check for a loose connection between the humidistat and sensor. If connections are ok, the sensor itself has an open circuit and must be replaced. **Do not test the sensor with a direct current ohm meter, as sensor calibration will be destroyed.**

8.3 Trouble Shooting Dryer Cycling Interruption



WARNING!

RISK OF ELECTROCUTION - Before performing this procedure: Disconnect from the electrical power source

8.3.1 Having found the dryer cycle to be interrupted (7.9), turn the dehydrator OFF and disconnect from power source before continuing! Disconnect one wire lead of each purge solenoid valve coil from the electrical connector in the dryer base plate. Measure the resistance of each coil with an ohmmeter. Normal coil resistance on 115 VAC is 100 +/- 10 ohms and for 230 VAC the resistance is 380 +/- 30 ohms. If either coil is open or shorted, replace the coil assembly. Be sure coil connections are secure when finished. If when the dehydrator is restarted, normal cycling is resumed, *proceed to 8.4, if not, to 8.3.2.*

8.3.2 If cycle interruption continues, replace the timer. When cycling is restored, *proceed to 8.4.*

8.3.3 Pressure fluctuation. If the back pressure falls to 0 PSIG at any time when the compressor is operating it indicates that one purge solenoid valve has failed to closed. This can be corrected by installing valve repair kit P/N 0024815022. Install kits in both valves so that both are in new condition. When the valve repair is completed and cycling is restored, proceed to *section 8.4*.

8.3.4 If DRY-PAK dryer cycling and back pressure are normal and if the dehydrator operates more than once each hour, replace the purge mufflers. If the purge noise is noticeably more sharp with the new mufflers installed, go to *section 8.4*. If all operational checks reveal no reason for the alarm condition, but the alarm persists, replace the sensing element. If the alarm persists, go to *8.4*.

8.3.5 If the humidity alarm repeatedly occurs and automatically clears after a period of continual operation, increase the back pressure regulator setting to 69 PSIG (476 kPa), 55 PSIG (379 kPa) on Model 3200. This type of humidity alarm is often the result of an exceptionally high-capacity compressor or of infrequent dryer operation. In either case the extra back pressure will eliminate the problem.

8.4 Dry-down after repair

If the cause of a valid humidity alarm has been corrected, the unit must operate after repairs are completed for perhaps an hour or more in order to dry the desiccant towers and clear the humidity alarm. If a defective sensor element was the cause of alarm, it will normally clear after 5 to 15 minutes of operation with a new sensor in place.

8.4.1 The desiccant used in the drying towers is molecular sieve, which has a normal useful life equal to the dehydrator. Reduced service life can occur due to air borne contaminants (hydrocarbons, acids etc.) which may plug or degrade the desiccant. This is seldom the cause of a high humidity condition, but if all other possible causes for a high humidity condition have been ruled out, and especially after years of service, replacement of the dryer desiccant towers is recommended.

8.4.2 If none of the above procedures solve the humidity alarm, replace the DRY-PAK dryer.

9.0 Service Information

Should you need to contact us please call our Customer Service Department on (207) 655-8525 or Tool Free at (877) 247-3797.

When returning a equipment for factory service, call the customer service department for a Service Return Authorization number (SRA). the device should be boxed securly and contain contact information, contact telephone number, billing information, and return shipping information. If the device is being sent to the factory for service, a written statement of the problem of symptoms should be included. The SRA number must be on the outside of the package or indicated on the shipping label.

NOTE: Do not ship equipment contaminated with any type of hazardous/harmful substance.

SPX Dielectric
28 Tower Road, Raymond, Maine 04071
Phone: (207) 655-8525
Toll Free: 1-877-247-3797
Fax: (207) 655-8535
Email: rd.sales.us@spx.com

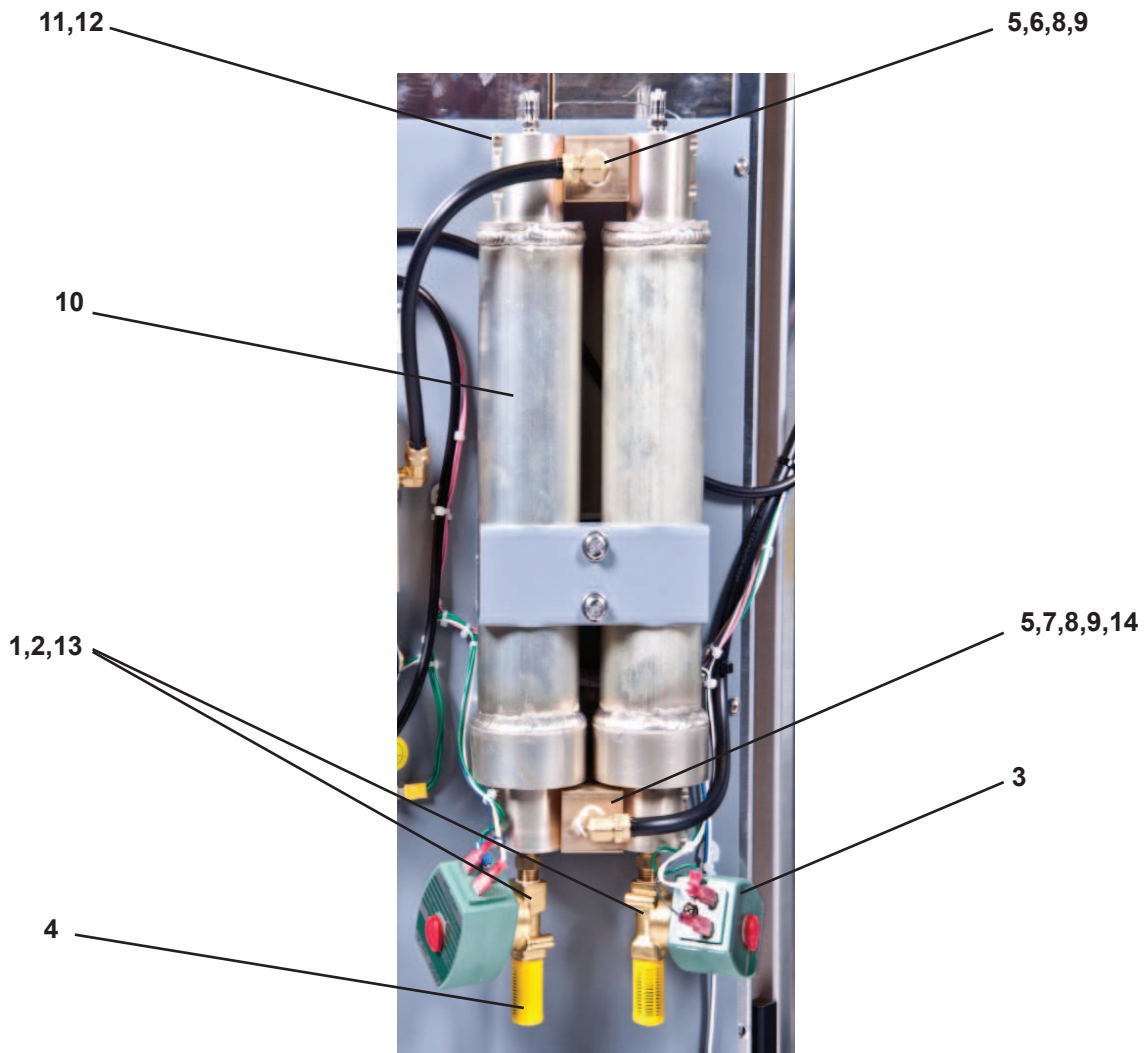

Figure 4
 DRY-PAK Dryer Assembly

1	Purge Valve -All 115v Models (2 required)	47047
2	Valve Repair Kit (mechanical parts)-ALL MODELS (2 required)	0024815022
3	Purge Solenoid Valve Electric Coil 115v, 60/50 Hz	47316
4	Purge Solenoid Valve Silencer (2 required)	0022646001
5	Ball Check (2 required)	0015903003
6a	Top Ball Valve Seat with drilled orifice for Model 2400 (2 required)	47314
6b	Top Ball Valve Seat with drilled orifice for Model 3200 (2 required)	60841
7	Bottom Ball Valve Seat (for All Models, no orifice, 2 required)	37393
8	Center Block	37392
9	Valve Seat O-ring Seal	0014000115
10a	Desiccant Cylinder Assembly for Model 2400 (2 required)	47114
10b	Desiccant Cylinder Assembly for Model 3200 (2 required)	45992
11	Desiccant Cylinder Socket Head Cap Screws	0011032150
12	Lock Washer for item 11	0161000000
13	1/4" Hex Nipple	0005538016
14	1/4" NPT x 3/8 Poly Flow Elbow	0016853013

TABLE IV - SPARE PARTS LIST

Item	Description	Application	Part No.	Qty
1	Electrical Module Assembly complete	2400	60629	1
1a	Electrical Module Assembly complete	(3200 only)	60839	1
2	Humidistat	All Models	34709	1
3	Air Quick-connect fitting - Male	All Models	0020507002	1
4	Air Quick-connect fitting - Female	All Models	0020507001	1
5	Alarm Relay	All Models	14126	1
6	Dryer Solid State Timer	2400 Only	63309	1
6a	Dryer Solid State Timer	3200 Only	13334	1
7	Excess Run Alarm Timer	All Models	47919	1
8	Nut, sensing element retainer	All Models	0020525001	1
9	O-ring, sensing element connector seal	All Models	89795	1
10	Shrader Valve for pressure testing	All Models	0017495001	4
11	Back Pressure Gauge (100 PSIG)	All Models	0017221082	1
12	Humidity Sensor Element	All Models	15688	1
13	Humidity Sensor Pressure Plug	All Models	30986	1
14	Back Pressure Regulator	All Models	0020523003	1
14a	Back Pressure Regulator Diaphragm	All Models	0020523012	1
15	Humidity Bypass Solenoid Valve	All Models	47049	1
16	Humidity Bypass Solenoid Valve Repair Kit	All Models	0024815021	1
17	Humidity Bypass Solenoid Valve Spare Coil	All Models	47318	1
18	Humidity Manifold Assembly	All Models	60628	1
19a	DRY-PAK Dryer Assembly- 115v, 60 Hz Model 2400		60626	1
19b	DRY-PAK Dryer Assembly- 115v, 60 Hz Model 3200		60840	1
20	Heat Exchanger	All Models	44746	1
21	Shock Mount, Compressor support	All Models	47045	4
22a	Compressor Module for 115v, 60 Hz Model 2400		47224	1
22b	Compressor Module for 115v, 60 Hz Model 3200		60830	1
23	Compressor Flexible Air Hose	All Models	0045024505	1
24	Line Pressure Regulator	All Models	0047976001	1
25	Tank Pressure Switch (controls Start/Stop)	All Models	0060353001	1
26a	Cabinet Ventilation Fan (manufactured before 9/1/2001)	All Models	47218	1
26b	Cabinet Ventilation Fan (manufactured after 9/1/2001)	All Models	81797	1
27	On/Off Control Circuit Breaker	All Models	14204	1
28	Compressor Circuit Breaker	All Models	47117	1
29a	Outlet Air Flow Meter for Model 2400		0024970001	1
29b	Outlet Air Flow Meter for Model 3200		47572	1
30	Line Pressure Gauge (30 PSIG)	All Models	0005390070	1
31	Tank Pressure Gauge (160 PSIG)	All Models	0005390071	1
32	Light, Power On (white)	All Models	13226	1
33	Light, Alarm (red)	All Models	13225	1
34	Air Storage Tank	All Models	0060129001	1
35	Dry Air Outlet	(location reference only)		
36	Alarm Terminal Board	(location reference only)		
37	Tank Pressure Relief Valve	All Models	0021085001	1
38	Compressor Contactor K1	All Models	47052	1
39	Elapsed Timer (Hour Meter)	All Models	92007	1
40	Strip Heater	All Models	60565	1
41	Temperature Sensor Switch	All Models	0020504002	1
42	Lightning Arrestor	All Models	104782	1
42a	Base, Lighting Arrestor	All Models	104783	1
43	Ground Fault Outlet	All Models	60564	1
44	Delay Timer	All Models	99325	1
45	Cabinet Filter	All Models	0028175002	1
46	Inline Check Valve	All Models	104300	1

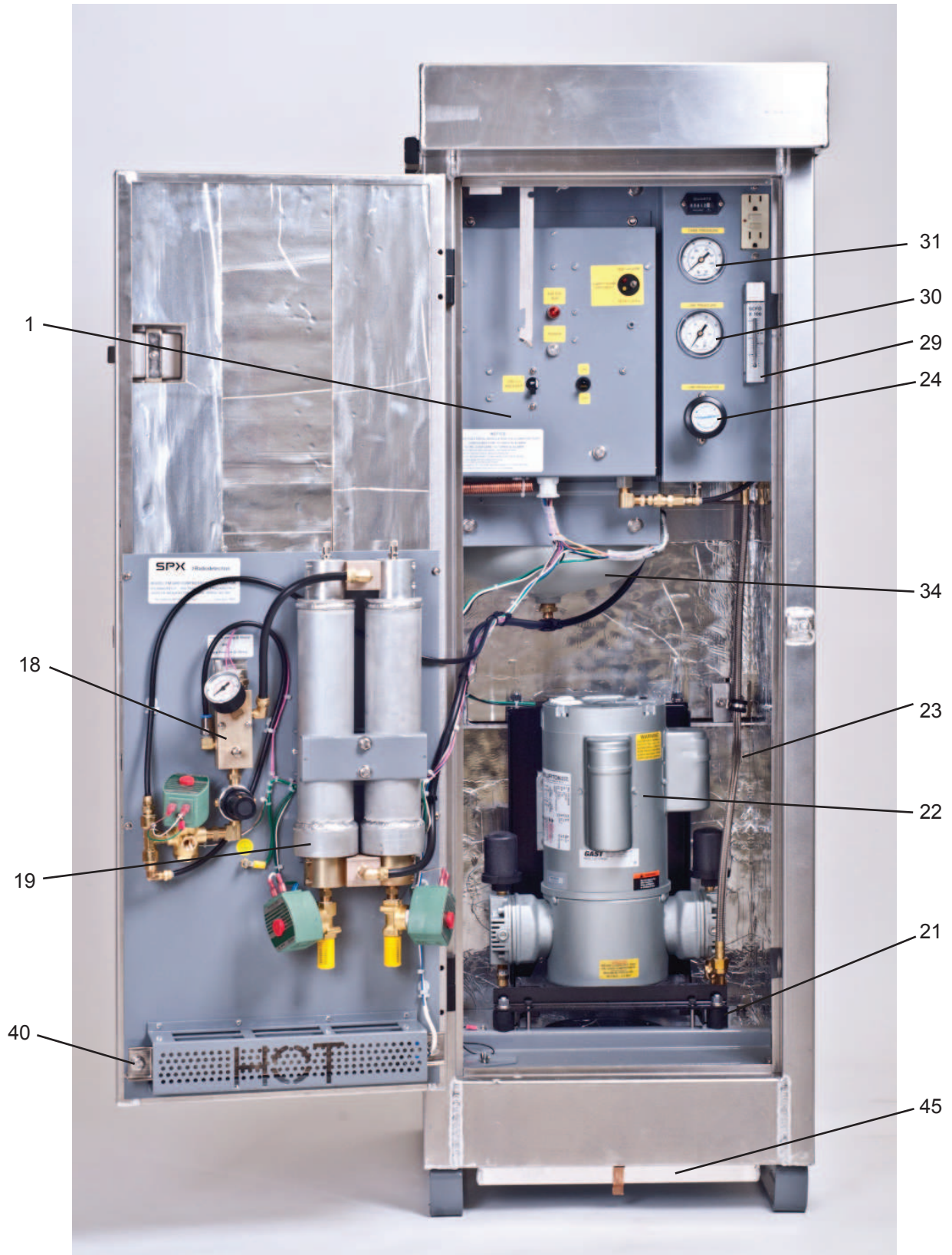

Figure 5
Pole Mount Dryer (front open)

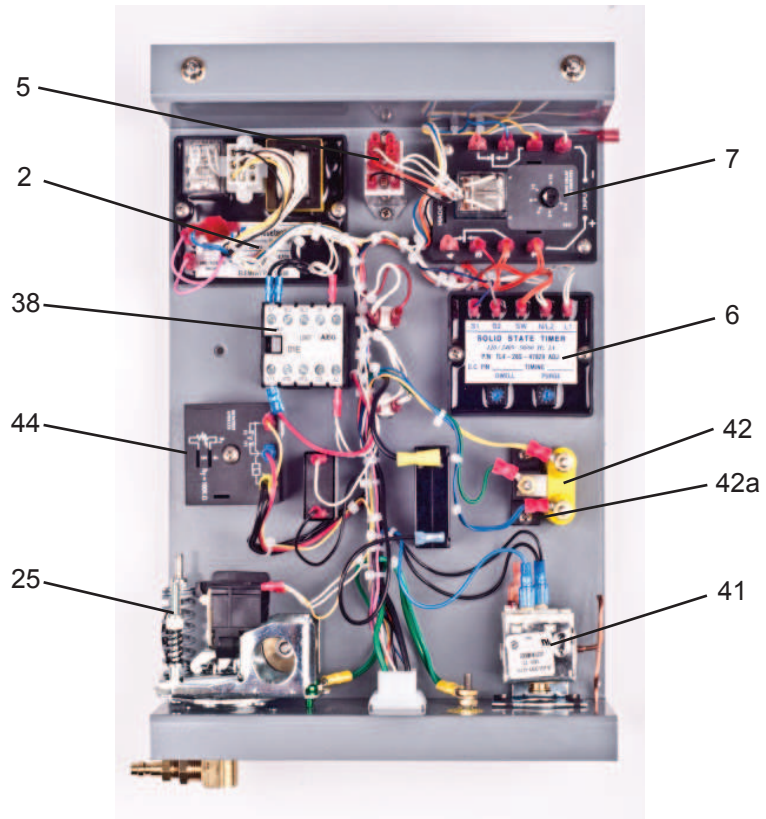

Figure 6
Electrical Module

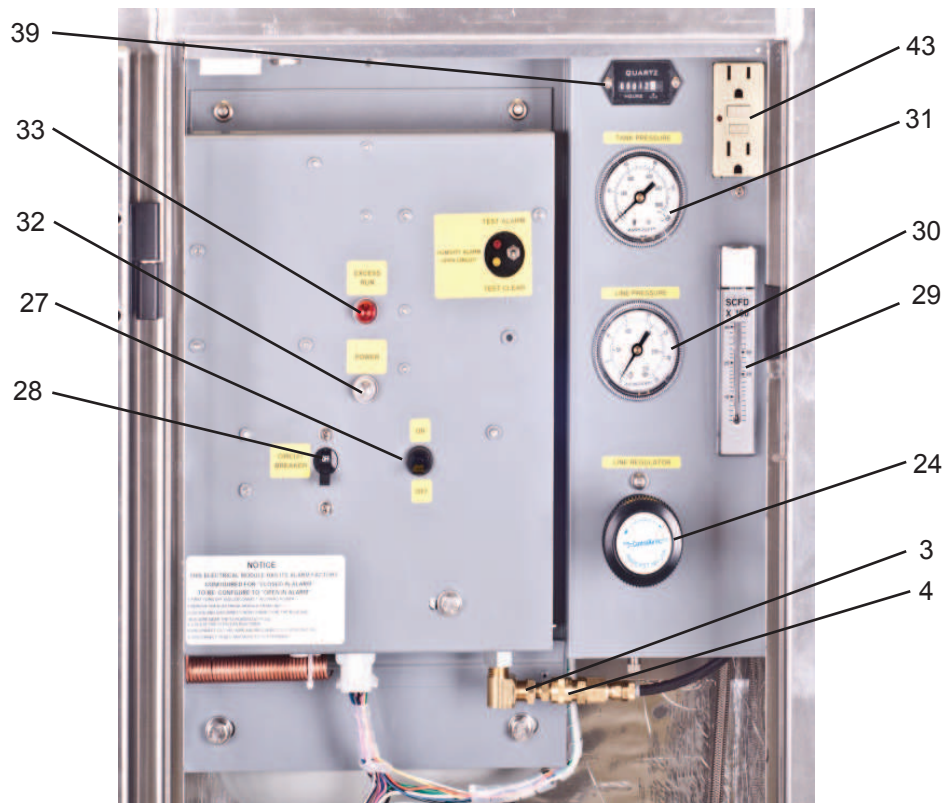

Figure 7
Electrical Module, Front View

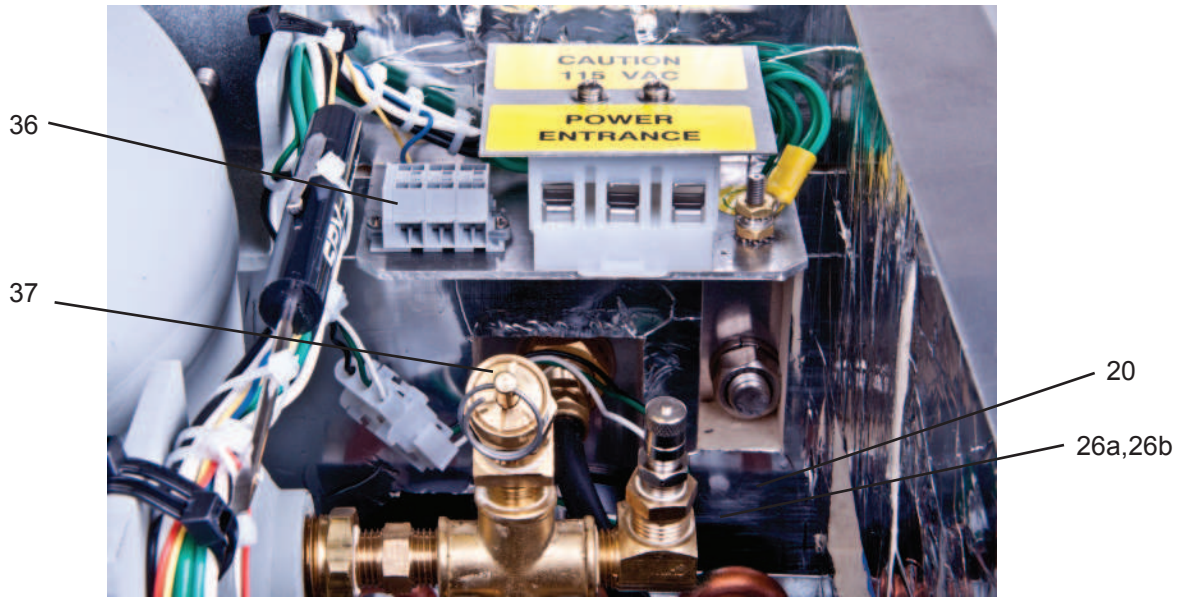

Figure 8
Pole Mount Dryer (open top view)

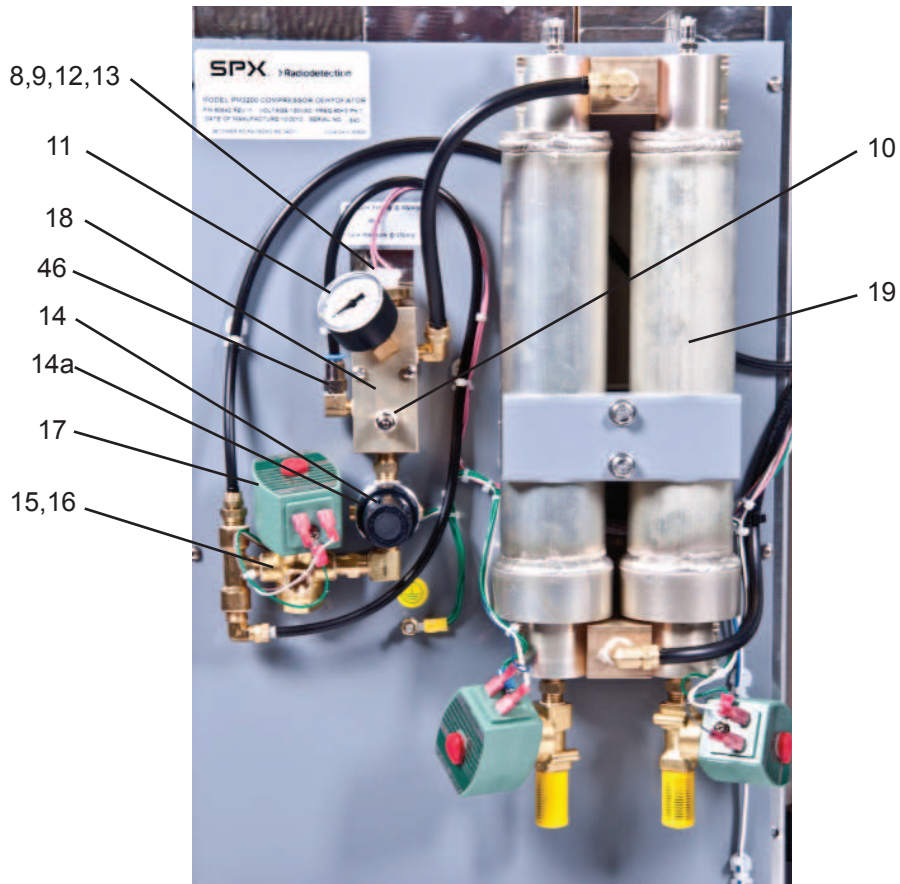

Figure 9
Heatless Dryer

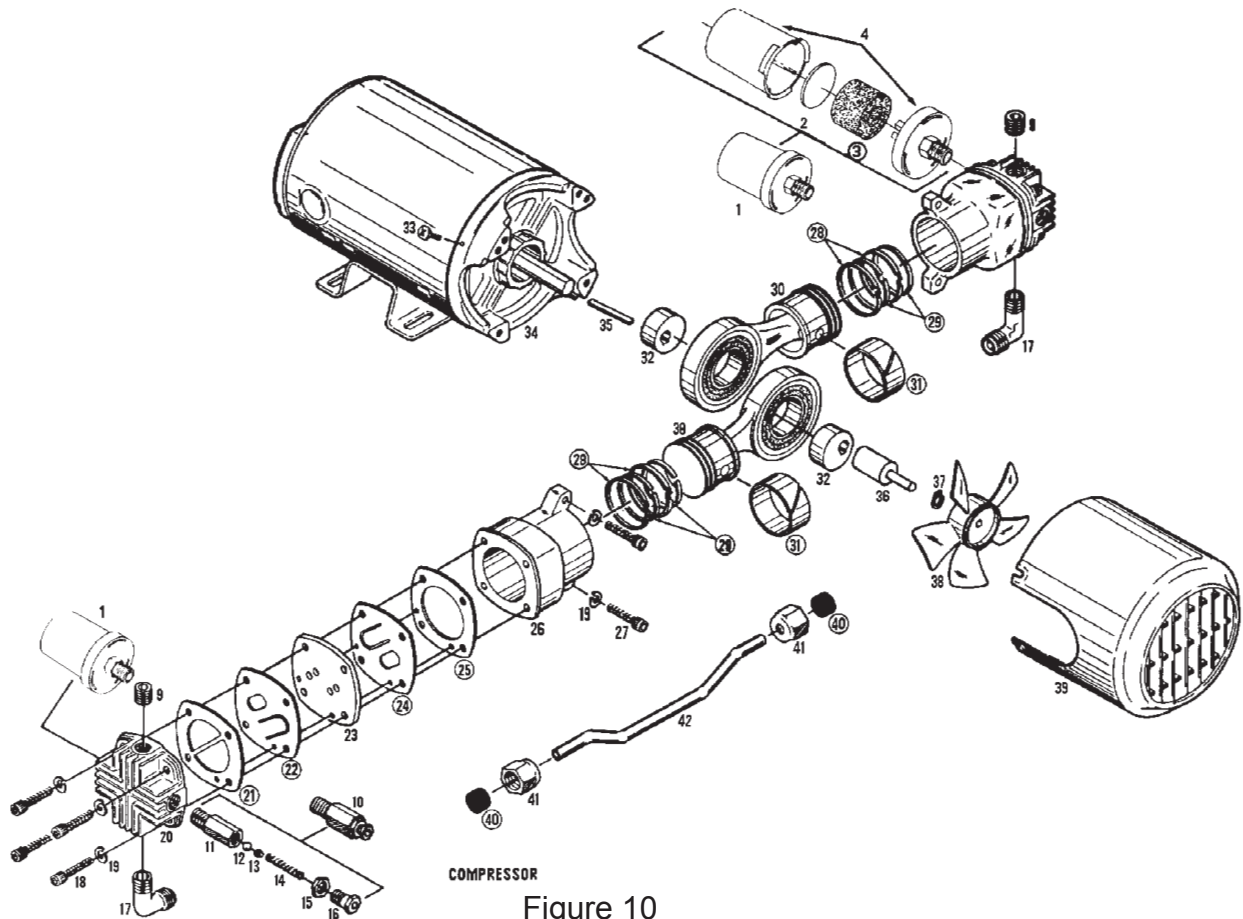

Figure 10
Compressor - Exploded View

SPARE PARTS LIST FOR COMPRESSOR

Item	Description	Qty	Part Number
1	Inlet Filter Assembly	2	0023601002
*3	Replacement Felt Element for Inlet Filter	2	0021990001
9	Pipe Plug	2	Reference
10a	Safety Valve (2400)	1	0023630001
10b	Safety Valve (3200)	1	0023630004
17	Manifold Elbow	2	Reference
18	Head Screw	8	Reference
19	Lock washer	12	Reference
20	Cylinder Head	2	0023631001
*21	Head Gasket	2	Reference
*22	Valve, Outlet	2	Reference
*23	Valve Plate	2	Reference
*24	Valve, Inlet	2	Reference
*25	Cylinder Gasket	2	Reference
26	Cylinder	2	0023637001
27	Cylinder Screw	4	Reference
*28	Piston Ring	4	Reference
*29	Piston Seal	4	Reference
30	Piston Rod Assembly	2	0023640001
*31	Piston Rider Ring	2	Reference
38	Fan Blade	1	0023643001
39	Fan Shroud	1	0041688025
*40	Manifold Sleeve	2	Reference
41	Manifold Nut	2	Reference
42	Manifold Tube	1	Reference

* = Parts contained in Maintenance Kit P/N 0027406501, for the routine maintenance of one compressor per kit.

Figure 11 ELECTRICAL DIAGRAM (115 V)

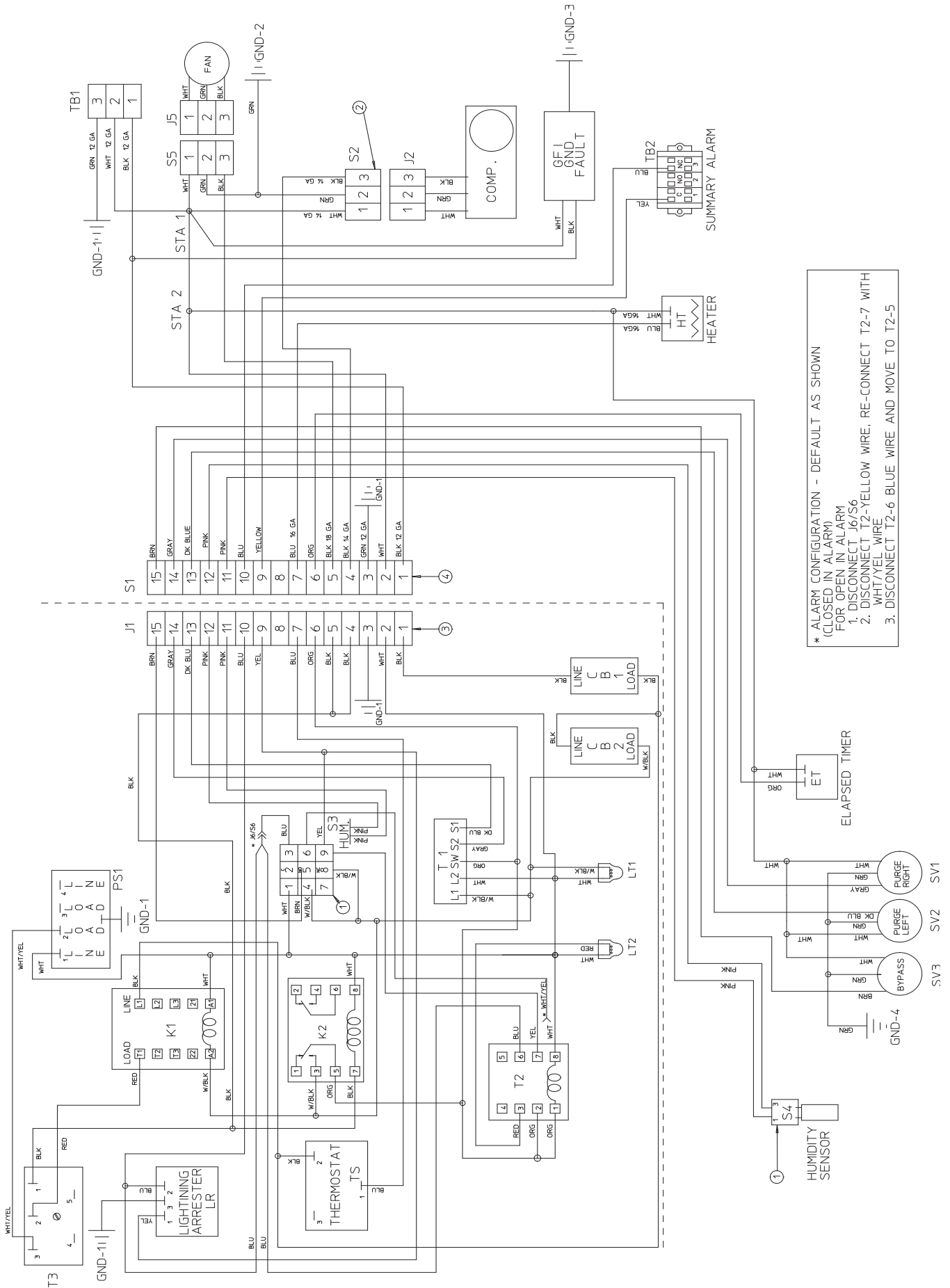

TABLE V
ELECTRICAL COMPONENTS - LOCATIONS and FUNCTIONS

CB 1 ---	20 amp, 1 pole COMPRESSOR CIRCUIT BREAKER, located on the electrical module -- provides current to CB-2 and to compressor via K1 and PS-1.
CB 2 ---	1.0 amp, 1 pole CONTROL CIRCUIT BREAKER, located on the electrical module -- provides current to LT1, coil of K1, to ET, S3 and also to SW terminal of T1 via K2.
COMP.---	OIL FREE COMPRESSOR/MOTOR ASSEMBLY, located in cabinet base.
FAN ---	Cabinet Ventilation Fan, located on cabinet rear surface --- powered by PS1.
HUM. ---	HUMIDISTAT, located on the electrical module -- provides current to SV3 when clear. Dry contacts (HUM/S3-3,, -9) report alarm condition to TB1.
J1/S1---	POLARIZED JACK AND SOCKET CONNECTOR, 15 pin - connect cabinet electrical harness to ELECTRICAL MODULE.
J2/S2---	POLARIZED JACK AND SOCKET CONNECTOR, 3 pin - connect cabinet harness to COMPRESSOR harness.
TS ---	THERMO SWITCH, for the strip heater.
ET ---	ELAPSED TIMER (HOUR METER), located on the tank panel -- shows the total hours of dryer and compressor operation.
K1 ---	CONTACTOR, located on electrical module -- provides current to compressor via PS-1.
K2 ---	RELAY, located on electrical module --- powers ET, T2 and T1-SW when PS-1 is closed.
LT1 ---	POWER ON INDICATOR (clear), located on electrical module --- illuminated via CB1 and CB2.
LT2 ---	Excess Run Alarm (red), located on electrical module --- illuminated by T2.
PS-1 ---	START/STOP TANK PRESSURE SWITCH, located on electrical module --- closes to operate compressor, hour meter, fan, and dryer when tank pressure declines to 25 PSIG (20 PSIG on 3200). The tank pressure switch opens when tank pressure increases to 60 PSIG (50 PSIG on 3200).
T1 ---	Dryer cycle timer, located on electrical module --- provides 25 seconds of current and 5 seconds of "dwell" (current interruption) alternately to SV1 and SV2 of the dryer. L1 and L2 of T1 are continually energized when the dehydrator is powered, providing the uninterrupted memory function which balances the work load on the desiccant towers of the dryer.
T2 ---	Excess Run Alarm Timer, located on electrical module --- provides power to LT2 and dry contacts report alarm condition to TB1 when compressor operates beyond adjusted limit.
S3 ---	POLARIZED SOCKET CONNECTOR, 9 sockets, located on the electrical module - connects module harness to HUMIDISTAT.
S4 ---	NON-POLARIZED SOCKED CONNECTOR, 3 sockets (center not used), located at HUMIDITY MANIFOLD inside cabinet door - connects to HUMIDITY SENSOR PRESSURE PLUG (J6, not shown).
SV1 ---	Normally closed PURGE SOLENOID VALVE, located at base of heatless dryer - operated by T1-S2.
SV2 ---	Normally closed PURGE SOLENOID VALVE, located at base of heatless dryer - operated by T1-S1.
SV3 ---	3 way BYPASS SOLENOID VALVE, located at lower left inside cabinet door - electrically energized by HUMIDISTAT (S3-5) when humidity alarm is clear, allowing dry air to flow to storage tank. Vents wet air through port #3 if in humidity alarm.
TB-1 ---	ALARM TERMINAL BOARD, located on rear inside bracket in the cabinet --- terminals for connection to remote alarm device.
HUMIDITY SENSOR-	Located inside manifold (17), connects to HUMIDITY SENSOR PRESSURE PLUG (J6) The sensor responds electrically to any change in moisture content of the dry air from the heatless dryer.

TABLE VI
GLOSSARY of TERMS

Altitude: The distance which the installation is above sea level expressed in feet, used interchangeably with elevation.

Ambient: The environment surrounding the dehydrator. Ambient factors which can influence a dehydrator include the temperature, the relative humidity, the atmospheric pressure and quantity of various pollutants which are present.

Desiccant: The component within the dryer towers which is used alternately to retain, then to expel moisture from the process air. Dielectric dryers employ desiccant which is totally inert, that is; it undergoes no chemical or physical change in normal use.

Dew Point: Expressed in °F., the temperature at which dew or frost would form at 14.7 PSIA. The dew point of a given air sample rises with increased pressure. In 1943 Dielectric established a dew point of -40°F. as standard for their compressor / dehydrators and for the pressurization of the communications equipment which is produced at Dielectric. NOTE: -40° is the one point at which the Fahrenheit and Celsius scales are numerically equal.

Heatless Dryer: A dryer consists of two desiccant towers, two maintenance free ball checks and two direct acting solenoid valves controlled by a solid state timer. The main air flow is handled by the ball checks without measurable pressure loss. Only the purge air flows through the two way solenoid valves, providing high efficiency and long trouble free service.

Elevation: The distance which the installation is above sea level expressed in feet, used interchangeably with altitude.

Line Pressure: The pressure of the low pressure outlet system, which is controlled by the adjustment of the Line Pressure Regulator, is displayed on the Line Pressure Gauge.

PSIA: Pounds per Square Inch Absolute. The measure of the pressure of a gas or liquid, expressed in pounds per square inch, relative to a total vacuum. Standard atmosphere at sea level equals 14.7 PSIA (approx.).

PSIG: Pounds per Square Inch Gauge. The measure of the pressure of a gas or liquid within a component or system, to the degree it is greater than that of the surrounding atmosphere, expressed in pounds per square inch. The internal pressure as shown on the gauges used on air dryers.

SCFD: Standard Cubic Feet per Day. A rate of air flow measured in cubic feet at 14.7 PSIA and 68° F. One SCFD when subjected to 10 PSIG (without temperature change) would occupy a space equivalent to 0.6 cubic feet.

Std. Conditions: Standard operating conditions imply a reasonably clean environment at 70°F. and sea level. Ambient conditions impact dryer maintenance needs.

Summary Alarm: An alarm which does not identify an individual condition, but which can indicate an active state of one or more alarm sensors within the dehydrator. Alarm terminations which either close in alarm or open in alarm, or dual function terminations may be available, dependent on design parameters.

System Pressure: The pressure at which the compressors and the drying towers (desiccant towers) operate. System Pressure determines the quantity of compressed air flow, the quantity of purge air and the moisture load on the desiccant towers.

WARRANTY

The Manufacturer warrants that all goods supplied hereunder, whether or not of its own manufacture, will be of the kind described herein or in any specification and drawing approved by the Manufacturer and free from defects in material or workmanship under normal use and prescribed maintenance for a period of one (1) year, with the exception of air dryers utilizing water sealed compressors as well as the compressors themselves which shall be for two (2) years. Neither this warranty nor any other, expressed or implied, shall apply to goods delivered hereunder which have been damaged or subjected to alteration or negligence after delivery. The Manufacturer's only obligation for breach of this warranty shall be the repair, without charge, or the furnishing EX Works Raymond, Maine, of a similar part to replace any part which within one (1) year, with the exception as noted above, from date of shipment is proven to have been defective, provided that (i) the Purchaser shall have notified the Manufacturer within ten (10) days of the discovery of such defect and not later than ten (10) days after the last day of this warranty, and (ii) the Manufacturer shall have the option of requiring the return of the defective material (transportation prepaid) to establish the claim. The Manufacturer shall not in any event be liable for the Purchaser's manufacturing costs, loss of profits, good will or any other special, consequential, incidental, or other damages resulting from such defects. THERE ARE NO OTHER WARRANTIES, EXPRESSED OR IMPLIED, WHICH EXTEND BEYOND THE WARRANTY SET FORTH HEREIN.

Radiodetection (USA) 28 Tower Road, Raymond, Maine 04071, USA
Tel: +1 (207) 655 8525 Toll Free: +1 (877) 247 3797 Fax: +1 (207) 655 8535 rd.sales.us@spx.com www.radiodetection.com

Radiodetection Ltd. (UK) Western Drive, Bristol BS14 0AF, UK
Tel: +44 (0) 117 976 7776 Fax: +44 (0) 117 976 7775 rd.sales.uk@spx.com www.radiodetection.com

© 2017 Radiodetection Ltd. All rights reserved. Radiodetection is a subsidiary of SPX Corporation. Dielectric is a trademark of Radiodetection in the United States and/or other countries. Due to a policy of continued development, we reserve the right to alter or amend any published specification without notice. This document may not be copied, reproduced, transmitted, modified or used, in whole or in part, without the prior written consent of Radiodetection Ltd.